

BUNCH-BY-BUNCH LONGITUDINAL RF FEEDBACK FOR BEAM STABILIZATION AT FAIR*

K. Groß[†], TEMF, TU Darmstadt, Germany

U. Hartel, U. Laier, D. Lens, K.-P. Ningel, S. Schäfer, B. Zipfel, GSI, Darmstadt, Germany

H. Klingbeil, GSI, Darmstadt, Germany; TEMF, TU Darmstadt, Germany

Abstract

To damp undesired longitudinal oscillations of bunched beams, the main synchrotron SIS100 of FAIR (Facility for Antiproton and Ion Research) will be equipped with a bunch-by-bunch feedback system. This helps to stabilize the beam, to keep longitudinal emittance blow-up low and to minimize beam losses. The proposed LLRF (low level radio frequency) topology of the closed loop feedback system is described. In some aspects, it is similar to the beam phase control system [1] developed at GSI Helmholtzzentrum für Schwerionenforschung GmbH. The differences and challenges are pointed out, which are mainly the bunch-by-bunch signal processing followed by the generation of a correction voltage in dedicated feedback cavities. The adapted topology was verified at SIS18 during beam time in 2014 using LLRF prototype subsystems and the two existing ferrite-loaded acceleration cavities. The experimental setup to damp coherent longitudinal dipole oscillations is presented and evaluated with focus on the realized modifications, including ongoing and pending investigations. Finally, the current status of the longitudinal feedback system for FAIR is summarized.

LLRF TOPOLOGY

Overview

Longitudinal coherent bunched beam modes can be classified by two numbers [2], the phase plane periodicity of individual bunches $m = 1$ (dipole), 2 (quadrupole), 3 (sextupole), ... with the oscillation frequencies $m\omega_{\text{syn}}$, where ω_{syn} is the synchrotron frequency, and the coupled bunch mode number $n = 0, 1, 2, \dots, M - 1$ quantifying the phase shift $2\pi n/M$ between oscillations of adjacent bunches for M equidistant identical bunches. In order to damp rigid bunch oscillations with $m = 1$ and $n = 0$ the beam phase control system acts on the phase of the standard acceleration cavities. Within the scope of the longitudinal feedback (LFB) system higher order inner bunch modes, in particular quadrupole oscillations ($m = 2$), will be included using multiple filters with different settings based on the mode frequency $m\omega_{\text{syn}}$. Arbitrary phase advances (mode number n) are covered by means of bunch-by-bunch signal processing and dedicated broadband kicker cavities.

Figure 1 gives a module-based overview of LLRF for the LFB system.

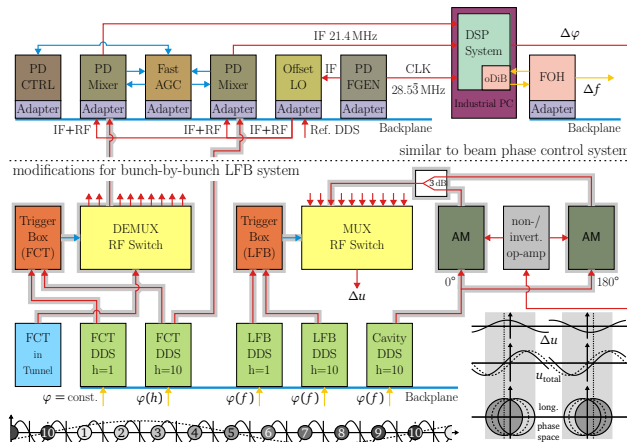

Figure 1: Sketch of LLRF of beam phase control system (top) with modifications for the LFB system (center) and principles of operation (bottom).¹

Bunch-by-Bunch Operation

The bunch-by-bunch signal processing is based on trigger units and fast RF switches for de-multiplexing (DEMUX) of the beam current as well as multiplexing (MUX) of the correction signal for the kicker cavities. The working principle of the trigger unit is illustrated in Fig. 1 (bottom left) for operation below transition energy. It relies on an RF harmonic² to change over to the next bunch and the revolution harmonic as reset. This allows unambiguous assignment of the bunches for the variety of ion species and energies at GSI as well as an arbitrary choice of harmonic numbers³. Copies of the setup are used to determine the excitation and the required correction voltage for each bunch. Thus, the multiplexed LLRF correction signal Δu comprises the calculated control outputs from all DSP (digital signal processor) systems, i.e. for all of the bunches.

In contrast to electron machines and storage rings, where bunch-by-bunch LFB systems are well-established, special attention has to be paid to the synchronization due to fast ramp rates and a considerable frequency span. Therefore, the gray-shaded paths are cut to length to reach all interaction points with the same time delay. The phase $\varphi(f)$ of the DDS

¹ Abbreviations not mentioned in the text: PD - Phase Detector (historical), CTRL - ConTRoLer, LO - Local Oscillator, FGEN - Frequency Generator, CLK - CLocK, FOH - Fiber Optical Hub

² The phase of the gap voltages (and thus of the bunches) is locked to that of the reference signals from DDS modules by means of local DSP systems.

³ adjusting $\varphi(h)$, as the point of measurement is naturally defined as phase with respect to one revolution, but independent of the (revolution) frequency (cf. $\varphi(f)$)

* Work supported by the German Federal Ministry of Education and Research (BMBF) under the project 05P12RDRBF.

[†] gross@temf.tu-darmstadt.de

(direct digital synthesis) unit actually driving the gap voltage has to be set according to the frequency-dependent phase response of LLRF components and cavity systems.

Analog Pre-Processing

For details including the hardware architecture we refer to [3]. The desired harmonic is extracted by frequency conversion, done in a mixer stage, followed by a bandpass filter at a fixed intermediate frequency (IF) of 21.4 MHz. Harmonics close to the IF have to be suppressed. For a continuous *beam* signal these components arise from the RF frequency, whereas for a de-multiplexed *bunch* signal they are caused by the revolution frequency, so that the 3 dB bandwidth of the filter was reduced by a factor of 10 to ± 25 kHz.

To make use of the dynamic range of the ADC stage and to allow level independent control algorithms, the beam signal has to be set to a fixed amplitude. For this purpose a digitally controlled variable gain amplifier (DCA) installed in the PD mixer module is used. The gain is adjusted by the automatic gain control (fast AGC) module depending on the actual detected amplitude. As the LFB system is meant to damp bunch length oscillation as well, an additional lowpass filter needs to be included to prevent the gain control to compensate those amplitude oscillations in the beam current. For the same reason steps in the signal are not tolerable, so that the DCA has to be replaced by a voltage controlled amplifier (VCA). With these modifications made the scaling of the beam current amplitude was laboratory-confirmed, though the particular (instantly available) components show some shortcomings and will be improved.

Digital Signal Processing

As it was done for the phase and amplitude detection algorithm [3, 4] the FIR (finite input response) filter implementation has been thoroughly tested on DSPs in the last years, and its functionality is now moved into FPGAs (field programmable gate arrays) located on the same hardware module as the DSP. New FPGA-based dynamically reconfigurable (tunable) digital filters were developed [5] and are currently integrated into the existent hardware architecture of the DSP-system to render testing possible. This will free programming power for new applications like parallel signal processing including multiple filters for different oscillation modes (mode number m).

Analog Post-Processing

Instead of applying the frequency correction Δf to the group DDS, i.e. to *all accelerating cavities*, the phase correction $\Delta\varphi$ is converted into an additional, phase shifted RF signal Δu and fed into *dedicated feedback cavities* resulting in an IQ modulation of the total voltage u_{total} seen by the beam (Fig. 1, bottom right). To transform the phase correction $\Delta\varphi$ provided by the DSP-system into an additive, amplitude modulated LLRF signal, a circuit with operational amplifiers (op-amp) and offset compensation was developed. It drives two amplitude modulators (AM) which are supplied with inversely phased RF signals by a DDS module. The

inversion of the modulation amplitude enables negative and positive phase adjustment using only available components.

BEAM TIME AT SIS18 IN 2014

Parasitic Measurements

In 2014 individual bunches have been tracked several times over complete SIS cycles at harmonic number $h = 2$ and $h = 4$. The experimental setup is similar to the one shown in Fig. 1 except for the used RF switches (Mini-Circuits, ZYSWA-2-50DR) with only two inputs/outputs. Figure 2 shows the separated longitudinal profiles of $^{238}\text{U}^{73+}$ bunches obtained from the de-multiplexed FCT (fast current transformer) signal during one of these measurements at $h = 4$. Thus, every fourth pulse in the beam current corresponds to the same particle bunch.

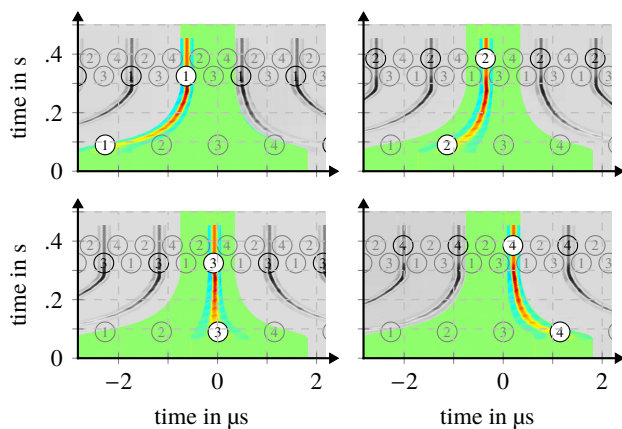

Figure 2: Tracking of single bunches during acceleration, full machine cycle, 11.4 - 1000 MeV/u (maximum rigidity). Only one revolution colored.

Principal Machine Experiments

Based on the experience gained with the subsystems described above, a prototype closed loop control system was built up at SIS18 to demonstrate the effect of beam stabilization. The relevant parameters of the experiments are summarized in Table 1. The extraction energy and the charge state were chosen such that the revolution frequency was within the operating range of the SIS18 ferrite-loaded cavities. Coupled bunch oscillations were excited by means of this revolution harmonic. To use one of the ferrite cavities as dedicated feedback cavity the phase synchronization and the tuning loop were switched off.

Table 1: Machine Setup on Oct. 16 and 18, 2014

Ion species	$^{238}\text{U}^{73+}$
Kinetic energy	300 MeV/u
Harmonic number	2
Revolution frequency	904.877 kHz
RF amplitude	2.4 kV
Theor. synchrotron frequency	443 Hz

The DDS-triggered de-multiplexing of the beam signal (Fig. 2) allows, in particular, for detection of coupled bunch oscillations, as intentionally excited on Oct. 16, 2014 (Fig. 3). Due to the constant mean value of the beam phase, this mode cannot be observed with the beam phase feedback system.

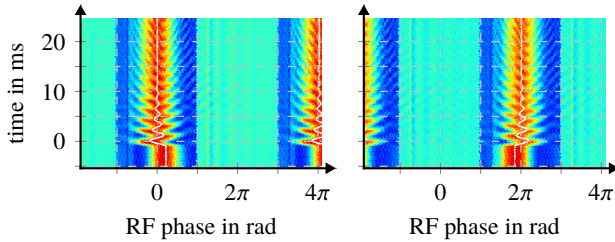

Figure 3: Waterfall plot of single bunches at $h=2$ with bunch-by-bunch phase detection $\Delta\varphi$ (white lines) using one DSP system per bunch for an out-of-phase excitation.

A triggered LLRF signal (Fig. 4, left) providing the correction voltage for an individual bunch (cf. Fig. 3, left) was generated for the first time on Oct. 18, 2014. An in-phase excitation was chosen due to the insufficient (quantity and) bandwidth of the available cavities⁴ that caused the gap voltage (Fig. 4, right) to act back on both ($h=2$) bunches.

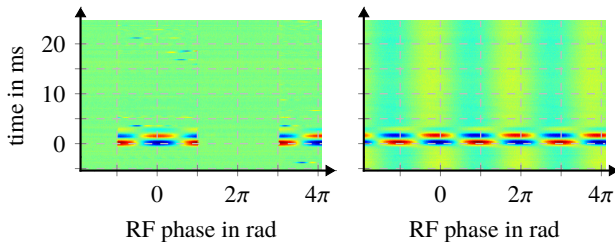

Figure 4: Multiplexed LLRF correction signal Δu (left) and resulting gap voltage in a ferrite cavity (right).

Figure 5 shows the bunch phase oscillations for two different excitation amplitudes, 40° (left) and 10° (right), with the feedback switched on and off. Regardless of minor persistent oscillations, due to the imperfect manual phase alignment of the gap voltage (cf. Fig. 4), the achieved damping of coherent dipole oscillations *proves in principle* the effect of beam stabilization and thus verifies the topology of the bunch-by-bunch LFB system.

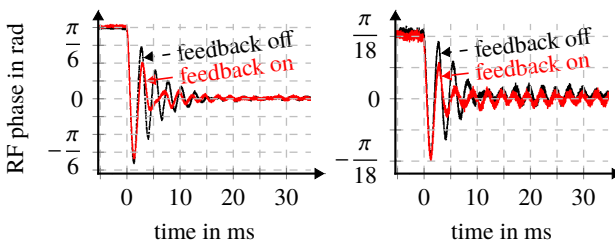

Figure 5: Comparison of open and closed loop operation.

⁴ The recently installed MA-based $h=2$ cavity unit was shut down because of a damage in the water cooling system.

Results from Further Experiments

It could be shown that during acceleration intentionally excited longitudinal coherent quadrupolar oscillations were damped significantly by the feedback system [6]. Previous experiments were only performed at fixed energy.

CONCLUSION AND OUTLOOK

The LLRF topology of the bunch-by-bunch longitudinal RF feedback system was defined. New subsystems including de-/multiplexing and post-processing were established and integrated into the existing LLRF system. In beam experiments the proposed system architecture was proven to work particularly with regard to

- the de-multiplexing of the beam profile from injection to extraction at maximum rigidity,
- the detection of coupled bunch oscillations,
- the generation of an additive LLRF correction signal to be used with dedicated feedback cavities and
- the achieved damping of coherent dipole oscillations as a *proof of principle* for the effect of beam stabilization.

Future work includes the (in-house) development of a VCA for broadband signals both for the gain control of the beam signal as well as the scaling of the gap voltage, and the completion of a specification for fast RF switches that can handle $h=10$ outputs/inputs for de-/multiplexing, respectively, to be used at SIS100. The recorded (LLRF) correction signal (Fig. 4, right) will be applied to a broadband kicker cavity system⁴.

ACKNOWLEDGMENT

The authors thank H. Liebermann and D. Ondreka for the support and the customized machine setup which allowed to use one of the two main ferrite cavities as dedicated feedback cavity, as well as M. Hardiek, F. Michler, D. Mondry and C. Thielmann for technical contributions and discussions.

REFERENCES

- [1] H. Klingbeil et al., "A digital beam-phase control system for heavy-ion synchrotrons", IEEE Trans. NS-54, No. 6 (2007).
- [2] F. Sacherer, "A longitudinal stability criterion for bunched beams", IEEE Trans. NS-20, No. 3 (1973).
- [3] H. Klingbeil, "A fast DSP-based phase-detector for closed-loop RF control in synchrotrons", IEEE Trans. IM-54, No. 3 (2005).
- [4] A. Guntoro et al., "Implementation of realtime and high-speed phase detector on FPGA", In International Workshop On Applied Reconfigurable Computing (ARC2006), Delft, The Netherlands (2006).
- [5] K. Möller et al., "FPGA based tunable digital filtering for closed loop RF control in synchrotrons", GSI Scientific Report 2013 (2014).
- [6] D. Lens et al., "Progress in damping of longitudinal beam oscillations during acceleration", GSI Scientific Report 2014 (2015).